

MADE IN ITALY



# SLIM

INCLINED PLATFORM LIFT FOR CURVED STAIRS



#### Optional:

- Foldable seat with seat belt.
- Wander lead with spiral cable for attendant control (available the version with joystick as well).
- Optical signalling device.

- Cover in 2 sizes: short, touch-sensitive, and long.
- Supports for floor call station.
- 2-ways emergency call system (GSM module).

The special **rope traction system** presents major benefits in respect of the traditional rack-and-pinion system commonly offered on the market: Slim can suit to **very narrow staircases** (min. passage required 895 mm), installation is possible both on the inner and outer side of the staircase as well as with very low headbulk. Slim is also silent when functioning and **comfortable for the user**.



Every component is **designed to occupy the minimum space** on the staircase and in the parking zones.



**Radio controls** to call the stairlift from the floor or send it to the parking position.



**Foldable seat** for users not on wheelchair.



**Wander lead** for attendant control, with spiral cable.



1. The **touch button panel** allows to move ergonomically the lift from board by simply touching with your fingers or palm the luminous arrows for ascend/descent, with no need to press on them.

2. The **overload led** and the **flashing light with sound alarm** fulfill compliance to the existing Safety Regulations both in private and public places.

3. The emergency button **stops immediately** the platform;

when pressed it sounds uninterruptedly, warning the user of any incidental pressing.

4. The **innovative electronic system** allows to keep constant track of the state of functioning, it considerably **simplifies diagnostics** and allows the installer to **customize the main parameters** according to the user's needs at any time.

# TECHNICAL FEATURES OF SLIM PLATFORM LIFT

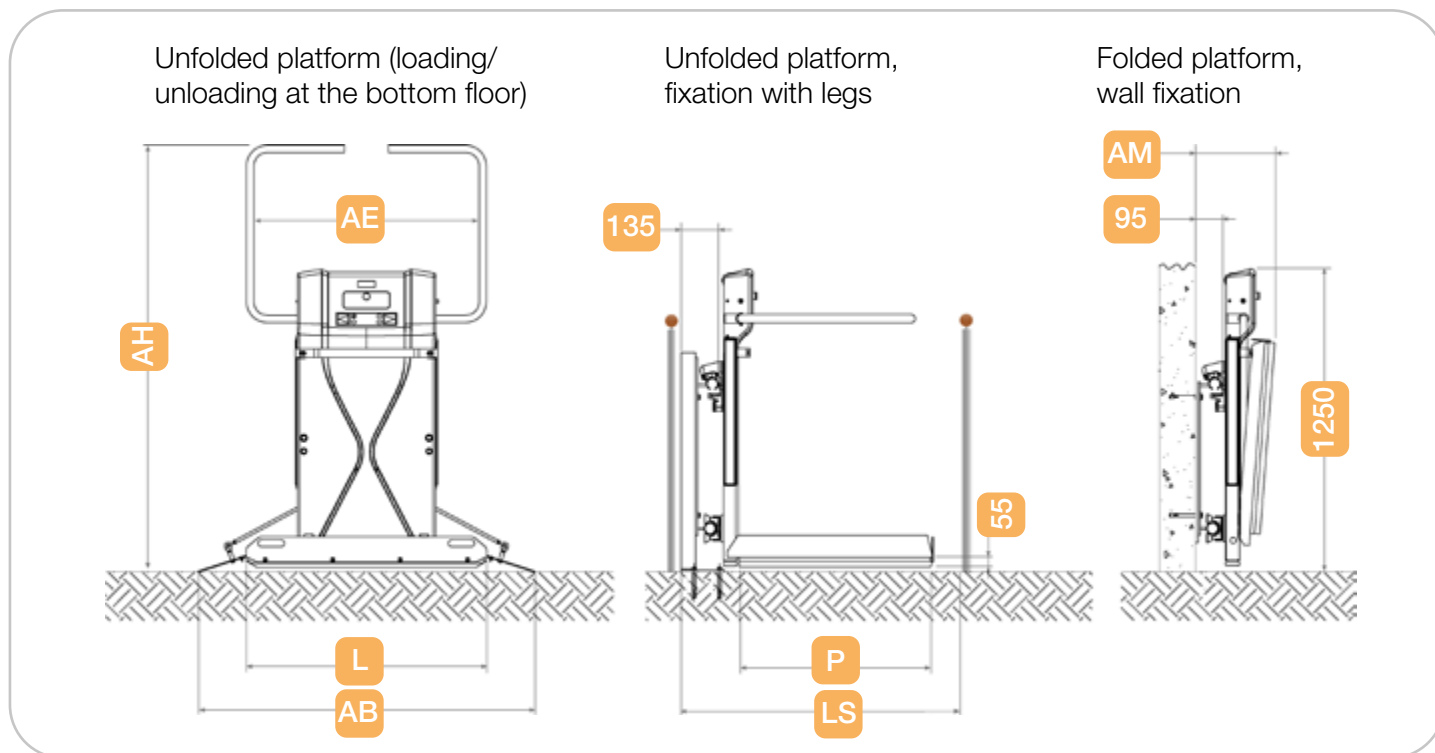

Platform dimensions (LxP)	750x600	750x650	750x700	850x700	1000x800	1250x800
<b>AB</b> Overall platform length	1130	1130	1130	1230	1400	1650
<b>AE</b> Overall useful length within barrier arms	745	745	745	825	975	1225
<b>AH</b> Overall height unfolded platform	1640	1690	1690	1690	1765	1765
<b>LS</b> Minimum stair width (wall fixation)	895	935	975	1005	1130	1215
<b>LS</b> Minimum stair width (fixation with legs)	935	975	1015	1045	1170	1255
<b>AM</b> Folded platform (wall fixation)				305		
<b>AM</b> Folded platform (fixation with legs)				345		
Technical data		Colours				
Load capacity	250 Kg (300 optional)	Platform (*)		Dark Grey (shade similar to RAL 7011)		
Speed	0,10 m/s	Fixings (*)(**)		RAL 9006		
Main voltage	100-240Vac 50-60Hz	Rails (*)(**)		RAL 9006		
Control circuits voltage	24V DC	(*) Other RAL colours available on request				
Power	0,75 ÷ 2,2 kW	(**) Hot galvanised (outdoor installations)				
Soft-start and soft-stop system	standard fitted	Certification				
Gradient:	Variable from 0° up to 55° (with inclination between 0° and 19° a third rail will be added). For the lifts with capacity 300 Kg. the inclination can vary from 20° to 55°.	Certificate N°: IMQ 342 Rev.0				
		Issued by: IMQ				
		Notified body N°: 0051				
		IP Rating: IP 54				

All dimensions are expressed in millimeters and all information contained in this catalogue have to be ment purely indicative. Extrema reserves the right to change at any time the information here reported without prior notification.

**Extrema S.r.l.**  
Via dell'Industria 2  
46031 Bagnolo San Vito (MN) - I  
Tel. (+39) 0376 252443  
Fax (+39) 0376 251091  
extremalifts.eu

**extrema**  
solutions in motion

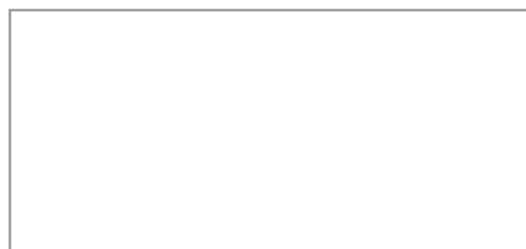

Rev.04 del 11/23

For further information see our website [extremalifts.eu](http://extremalifts.eu)