



VERTICAL LIFTING PLATFORM

PH-300

TECHNICAL SPECIFICATIONS

Contents

1. General description.....	Page 2
1.1. Application	Page 2
1.2. Regulations.....	Page 2
1.3. Characteristics	Page 2
2. Detailed description	Page 3
2.1. Drive and guiding.....	Page 3
2.2. Machine	Page 3
2.3. Vehicle	Page 3
2.4. Upper-level door	Page 5
2.5. Options	Page 5
2.6. Installation	Page 6
2.7. Control	Page 7
2.8. Safety elements.....	Page 7
3. Dimensions for installation.....	Page 9
3.1. Travel up to 500 mm, 180° accesses	Page 9
3.2. Travel up to 500 mm, 90° accesses	Page 10
3.3. Travel over 500 mm, 180° accesses	Page 11
3.4. Travel over 500 mm, 90° accesses	Page 12
3.5. Upper-level door.....	Page 13
3.6. Other cabinet locations.....	Page 14

1. General description

1.1. Application

Lifting platform intended for the vertical transport of persons with impaired mobility for operation between two defined landing levels in houses, commercial establishments and public buildings.

The lifting platform does not require a pit and is intended to be installed without a shaft closure.

The dimensions and rated load are appropriate for a passenger either in a wheelchair or standing up. They are appropriate for users of both manual and motorised and compact and maneuverable wheelchairs for indoor use and which may overcome some obstacles outdoors (classes A and B according to the European standard EN 12184), as well as for medium-sized scooters. The range of dimensions and the boarding layouts mean that wheelchairs can turn on the platform surface in the event of a 90° boarding layout.

1.2. Regulations

The lifting platform complies with the 2006/42/EC Machinery Directive and may, therefore, be commercialised in any country in the European Union. It is also made in accordance with the ISO 9386-1:2000 international standard.

1.3. Characteristics

Rated load (Q) 300 kg

Rated speed (v) 0.1 m/s

Travel (R) Up to 1.5 metres

Type of drive Direct acting hydraulic drive

Electrical characteristics 230 V \pm 5% single-phase 50/60 Hz
Other single-phase voltages available.

The power draw at full load may reach 900 W (3.9 A at 230 V).

2. Detailed description

2.1. Drive and guiding

Drive	<p>Direct acting hydraulic drive and side push effect.</p> <p>Cylinder with a safety valve and bottom oil feed. Depending on the travel of the lifting platform, this may be a simple cylinder or a double-acting telescopic cylinder, in both cases with a 35 mm diameter piston.</p>
Guiding	<p>A column is supplied for guiding the lifting platform, formed of a welded structure made of UF50.100.4 profiles that are inter-braced, which means the carriage moves along roller guides that operate inside the profiles.</p> <p>The lift has a guiding column supplied in a single section and with the cylinder and carriage already installed.</p>
Finish	<p>Welded assembly and protection panels painted with epoxy-polyester paint in colour RAL 7035.</p>

2.2. Machine

	<p>Both the hydraulic power unit and the electric components are located inside a small and compact cabinet. This cabinet is intended to be installed adjacent to the lift guide, on either the lower or upper level (see lower-level installation details in section "3. Dimensions for installation" and upper-level installation details in "3.6. Other cabinet locations").</p> <p>As an option, the cabinet may be located in a position not adjacent to the guide and different to any of the above, at a maximum distance of 10 metres from the guide assembly (see "3.6. Other cabinet locations").</p> <p>The cabinet is not designed to be installed outdoors.</p>
Hydraulic power unit	<p>Hydraulic power unit with an external motor and gear pump. There is a descent solenoid valve, a non-return valve and an overpressure valve integrated in the valve block, which also includes a pressure gauge with a protection valve. A manual descent push button is included in the block as means for emergency actuation to rescue passengers. A return filter and a shut-off valve are also included in the hydraulic power unit.</p>
Electric board	<p>The control board is located inside the cabinet and consists of the following components: main switch, motor circuit breaker, contactors, transformer, battery packs and the board for the main control of the lifting platform.</p>
Finish	<p>Cabinet painted with epoxy-polyester paint in colour RAL 7035.</p>

2.3. Vehicle

	<p>The vehicle has a platform sized appropriately for use by persons in a wheelchair and with a folding ramp along the access edge to the platform on the lower level.</p> <p>There is antislip material on the surface of both the platform and the access ramp to make access to the platform easier.</p> <p>There is a high-resistance plastic shell with an integrated handrail on the upper side of the side protection of the platform, on the side of the guide assembly.</p>
Fixed barriers	<p>On the non-access edge of the platform, there are fixed protection barriers to prevent falling from the platform. They consist of a roll-off guard and a tubular rail with two bars situated at a height of 300 mm and 1100 mm from the platform floor.</p>

The protection rail is not included with lifts with a travel equal to or less than 500 mm nor when there is a surface adjacent to this side which is vertical, continuous and solid, which covers the whole of the platform size and which is situated at a distance of 20 mm from the platform floor.

Mobile barriers

There are two mobile protection barriers on the access edge of the platform on the lower level. These consist of two arms, situated at 300 mm and 1100 mm from the platform floor, which are motorised, have a synchronised movement and which operate fully automatically during access to the platform.

Mobile protection barriers are not included in lifts with a travel equal to or less than 500 mm.

Access layout

There are different access layouts, depending both on the available space to access the platform on the upper level and the position of the guide with respect to the access to the platform.

In 180° boarding layouts, access to the upper level is also in a parallel direction to the wall on which the guide is fixed, while in 90° boarding layouts access to the platform on the upper level is in a perpendicular direction to the wall on which the guide is fixed.

See the recommended minimum access dimensions in each layout in section "3. Dimensions for installation".

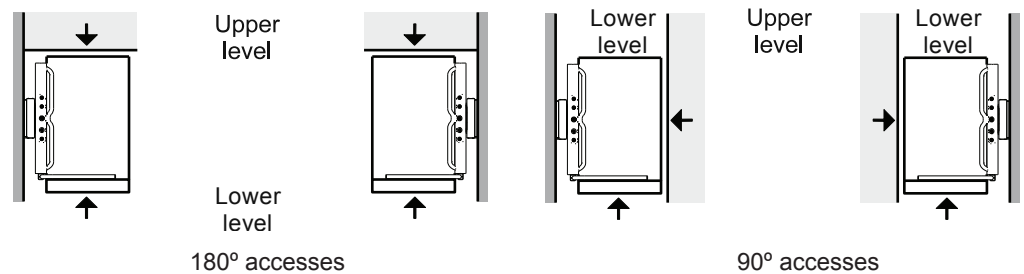

Platform dimensions

Depending on the access layout. See dimensions in section "3. Dimensions for installation".

Layout	Width (mm)	Depth (mm)
180°	800*	1250
90°	900**	

(*) As an option, smaller platform widths are available for installations with very small-sized shafts.

(**) As an option, smaller platform widths are available, adapted to the specific dimensions of the available shaft.

These small platform widths may not be compatible with the use of some wheelchair models.

Finish

Enclosures, platform and access ramp painted with epoxy-polyester paint in colour RAL 7035.

Mobile and fixed protection barriers painted with epoxy-polyester paint in colour RAL 7005.

Black antislip strips in platform and access ramp.

Upper plastic shell in colour RAL 7005.

Options

Glazed fixed protection handrail.

2.4. Upper-level door

An upper-level door is included to prevent against falling from the upper level in lifting platforms with a travel of more than 500 mm.

A single-leaf semi-automatic hinged door without a lintel and a height of 1,100 mm.

There is an electrically actuated lock in compliance with the EN 81 standard series, with a safety contact to control the locked position and with an emergency unlocking using a standard triangular key.

With an electric safety contact to control the locked position of the door.

Automatic option

Automatic actuation using a direct-current gear motor controlled by an electronic circuit with a microcontroller and operation completely integrated with the lifting platform control. The automation system is integrated in the inside of the post on the hinged side of the door.

Dimensions

Height (H): 1100 mm

Clear opening (PL): 800 mm (standard for the 180° access layout)
900 mm (standard for the 90° access layout)

Hand

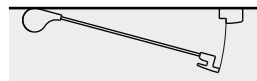

Left hand

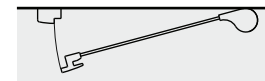

Right hand

Finish

Glazed leaf.

Posts and aluminium handle painted with epoxy-polyester paint in grey colour RAL 7035.

2.5. Options

Colour

Enclosures of the vehicle, platform, access ramp, welded structure and enclosures of the guide, posts and handle of the upper-level door painted in other colours in the RAL chart.

Outdoor installation

High-corrosion resistant finish and waterproof electrical installation for outdoor installations. Corrosion protection via cathodolysis treatment on the welded structures of the guide and vehicle, as well as on the protection barrier arms and rail and finish painted with polyester paint. The cabinet is not designed to be installed outdoors.

2.6. Installation

Location

The guiding column is intended to be fastened to the floor on the lower level and to one of the side walls of the shaft.

On the side wall, the guide is intended to be fastened at the height of the upper level slab and at the top end of the guide. Alternatively, when there are no structural elements to which to fasten the top end of the guide, double fastening at the height of the upper level slab is provided for. All of the material needed to fasten the guide assembly using chemical anchorages is supplied.

The reaction forces transmitted to the wall on which the guide is fastened are specified in the assembly instructions.

The wall opposite the boarding edge on the upper level must have a vertical, continuous and solid surface without projections along the whole size of the platform. The side wall to which the guiding column is fastened must also be vertical, continuous, solid and without projections.

If there are elements on the non-boarding platform edge, their surface characteristics depend on their distance from the platform.

See more details on surfaces and surface requirements in section "3. Dimensions for installation".

Electrical and hydraulic

The hydraulic installation is supplied completely pre-assembled and requires only a connection between the hydraulic power unit in the cabinet and the guide. Connection is via metal double-mesh flexible hydraulic hoses, individually tested for pressure together with the corresponding connectors.

The electrical installation is also supplied completely pre-assembled, with the wiring in the vehicle and the guide assembly fully installed; only the connection between the vehicle and the guide assembly is required (with plug-in connectors), along with the connection to the guide assembly, the landing push-button panels and, where applicable, the upper-level door to the cabinet.

When the machine cabinet is installed in the intended position adjacent to the guide assembly, both on the lower and upper levels, a distribution channel is supplied to accommodate both the hydraulic piping and the connection wires between the guide assembly and the cabinet, so that they remain hidden.

In the case of landing push-button panels to assemble on the surface (see complete description in section "2.7. Control"), distribution channels are supplied to accommodate the connection wires between the push-button panels and the cabinet, so that they remain hidden, reducing the need for preparatory work.

Upper-level door

The door is intended to be fastened on the floor of the upper level to make a uniform and continuous surface towards the inside of the lift shaft on the boarding edge (see "3. Dimensions for installation").

All of the material required to fasten the door to the floor is supplied, and no lateral fixation to other elements is needed. Depending on the construction type available under the flooring, two types of fixation are available:

- Directly on the flooring. It requires that the structural concrete be near the flooring and that the wall is not coated. In case the wall is plastered, the plaster needs to be of reduced thickness. This type of fixation requires no construction preparation. See "3.5. Upper-level door".
- With a base plate buried under the flooring and fixed to the structural concrete. The maximum admissible depth is 100 mm, and the plaster or covering of the wall may be a maximum of 35 mm. This type of fixation requires construction preparation. See "3.5. Upper-level door".

2.7. Control

Controls in vehicle

Integrated in the upper shell and situated at a height suitable for wheelchair users. The following elements are included:

- Key enabling switch for restriction of use.
- Independent ascent and descent push buttons, with light indication of the actuation of the buttons.
- Emergency stop push button with light indication of the actuation of the button.
- Acoustic and light overload indicator.

Landing push-button panels

There are two models of push-button panels: to recess in the wall at each landing level (standard) or with a box for surface assembly (as an option). For lifts with an upper-level door, the upper-level push-button panel is integrated in one of the door posts.

Recessed push-button panels with control elements assembled on a stainless steel sheet.

Surface-mounted push-button panels with control elements assembled on a connection box.

As an option, wireless surface landing push-button panels for a cable-free installation.

The following elements are included in the push-button panels.

- Key enabling switch for restriction of use.
- Call push button for the lifting platform, with light indication of the actuation of the button.

Control features

Control based on integrated electronics with microcontroller with the following main features:

- Movement of the platform with hold-to-run control, both from the platform push buttons and from the landing push-button panels.
- Priority of the platform commands over the landing push-button panel commands.
- Landing detection with final limit switches.
- Automatic control of the positioning of the platform boarding ramp and the protection barrier arms, where applicable, both from the landing push-button panels and from the vehicle commands.
- Movement of the vehicle is subject to the horizontal position of the protection barrier arms and to the lifted position of the access ramp.
- Releveling on the upper level with the door open.

2.8. Safety elements

Among all the safety and protection measures included in the lifting platform, the following may be highlighted:

General

- Safety valve as a means of protection against free fall in case of rupture of the piping.
- Mechanical locking of the protection barrier arms and access ramp with electric control.
- On lifting platforms with an upper-level door, electric control of both the closure and locking of the electric lock.

- Relevelling system on the upper level even with the upper-level door open as a safety measure against creepage.
- Upper final limit switch.
- Control of maximum motor and electrovalve electric supply time.

Use

- Tray under the platform floor as an obstacle detection device. In the event of detecting an obstacle, it allows the vehicle to move upwards.
- Load control system with pressure transducer.
- Emergency stop button in the vehicle.
- Battery-operated descent operation to the lower floor with automatic opening of the protection barrier arms and access ramp ordered from the vehicle, in case of loss of power supply.
- Manual descent push button in the hydraulic power unit for rescue, in case of breakdown.
- Manual opening of the protection barrier arms and the access ramp with a triangular safety unlocking key for rescue, in case of breakdown.

3. Dimensions for installation

3.1. Travel up to 500 mm, 180° accesses

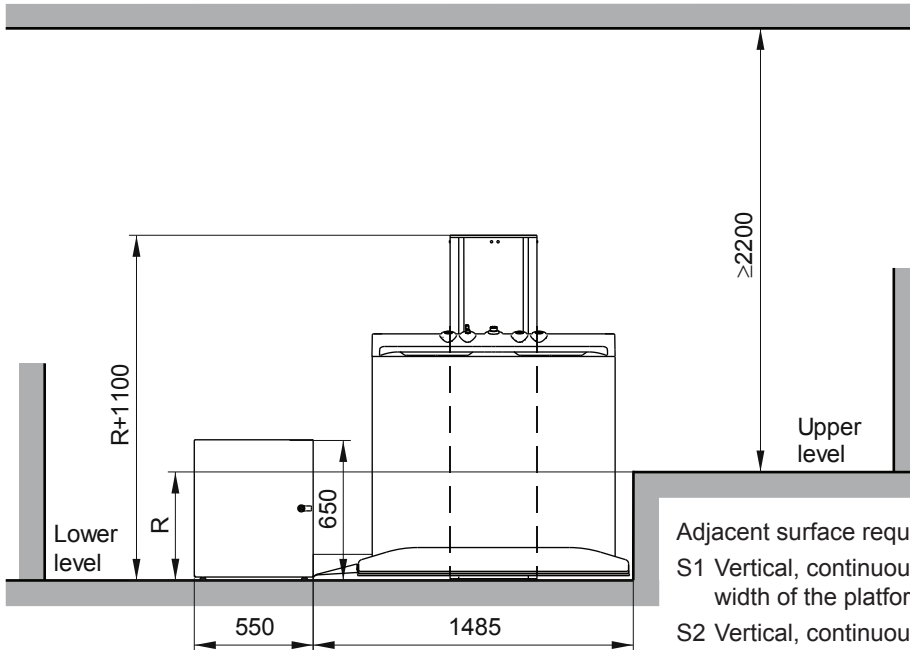

Adjacent surface requirements:

S1 Vertical, continuous, solid and smooth; throughout the width of the platform

S2 Vertical, continuous, solid and smooth

S3 According to the value of the distance to the platform (d):

d (mm)	Surface
≥20	Vertical, continuous, solid and smooth
≥120	Vertical, continuous and solid
≥400	No specific requirements

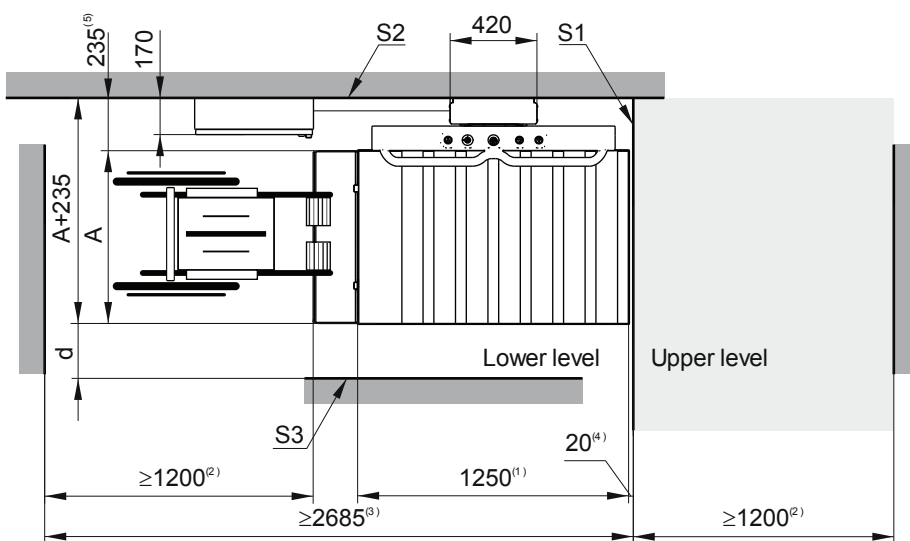

- R Travel
- A Width of the platform (standard 800 mm). Reduced width available as an option
- d Distance between platform and adjacent surface on the non-boarding edge
- (1) Depth of the platform

(2) Minimum space for use with a wheelchair (recommended 1500 mm)

(3) Total minimum space on lower level for use with a wheelchair (recommended 2985 mm)

(4) Distance between platform and boarding wall on the upper level

(5) Distance between platform and fastening wall

3.2. Travel up to 500 mm, 90° accesses

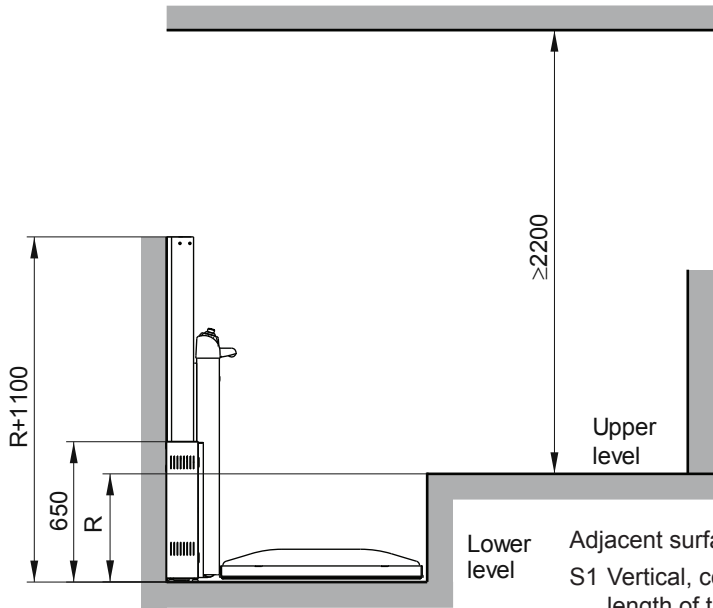

Adjacent surface requirements:

- S1 Vertical, continuous, solid and smooth; throughout the length of the platform
- S2 Vertical, continuous, solid and smooth
- S3 According to the value of the distance to the platform (d):

d (mm)	Surface
≥20	Vertical, continuous, solid and smooth
≥120	Vertical, continuous and solid
≥400	No specific requirements

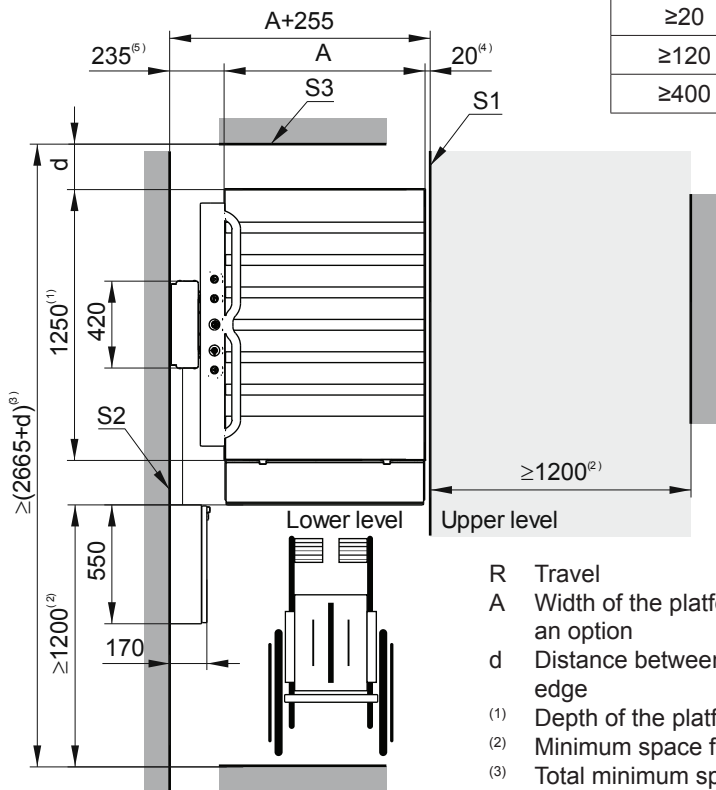

- R Travel
- A Width of the platform (standard 900 mm). Reduced width available as an option
- d Distance between platform and adjacent surface on the non-boarding edge
- (1) Depth of the platform
- (2) Minimum space for use with a wheelchair (recommended 1500 mm)
- (3) Total minimum space on lower level for use with a wheelchair (recommended 2965+d mm)
- (4) Distance between platform and boarding wall on the upper level
- (5) Distance between platform and fastening wall

3.3. Travel over 500 mm, 180° accesses

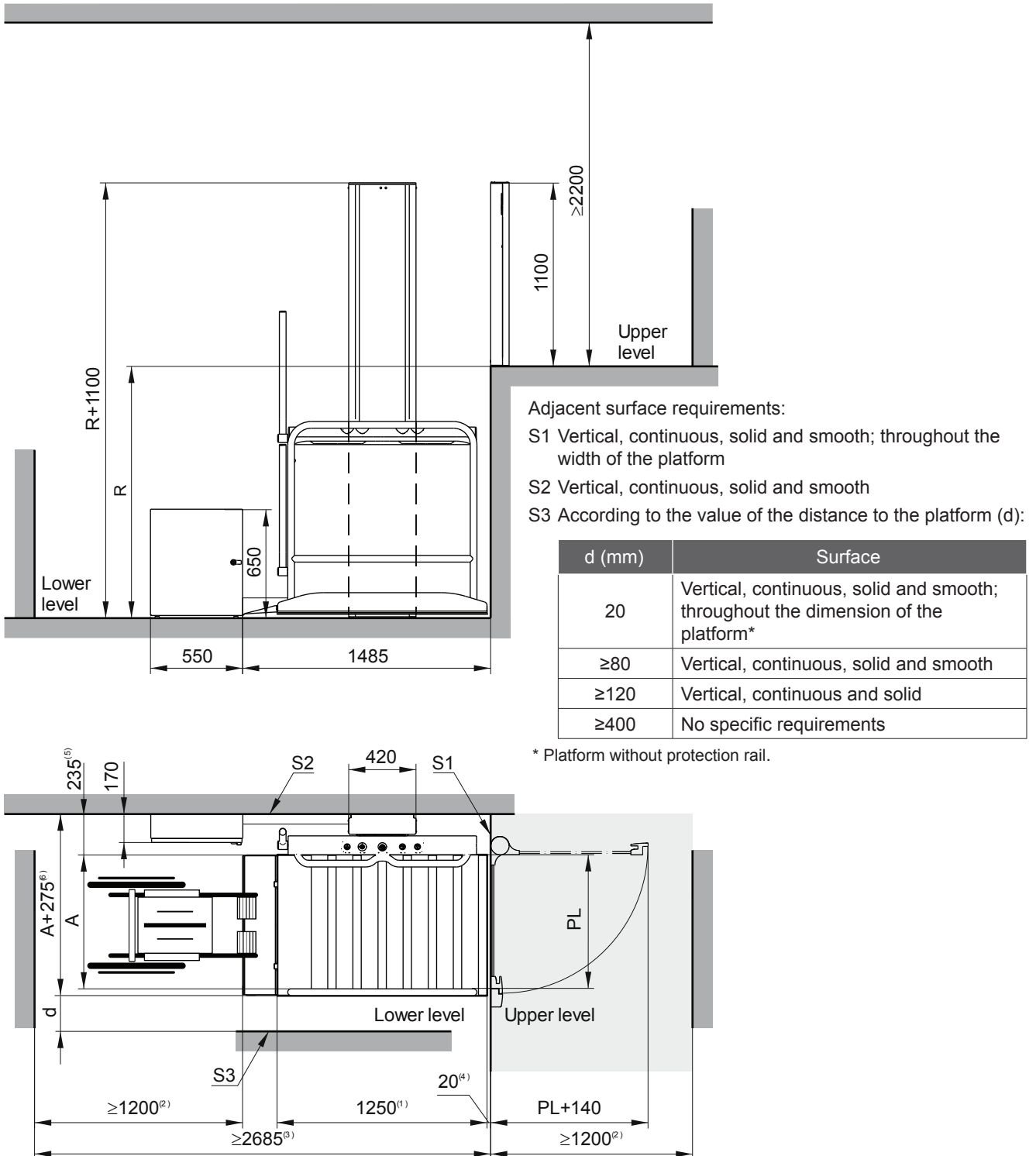

- R Travel
- A Width of the platform (standard 800 mm). Reduced width available as an option
- PL Clear opening (standard 800 mm)
- d Distance between platform and adjacent surface on the non-boarding edge
- (1) Depth of the platform
- (2) Minimum space for use with a wheelchair (recommended 1500 mm)

- (3) Total minimum space on lower level for use with a wheelchair (recommended 2985 mm)
- (4) Distance between platform and boarding wall on the upper level
- (5) Distance between platform and fastening wall
- (6) Distance between fastening wall and edge of the platform (A+235 for platforms without handrail)

3.4. Travel over 500 mm, 90° accesses

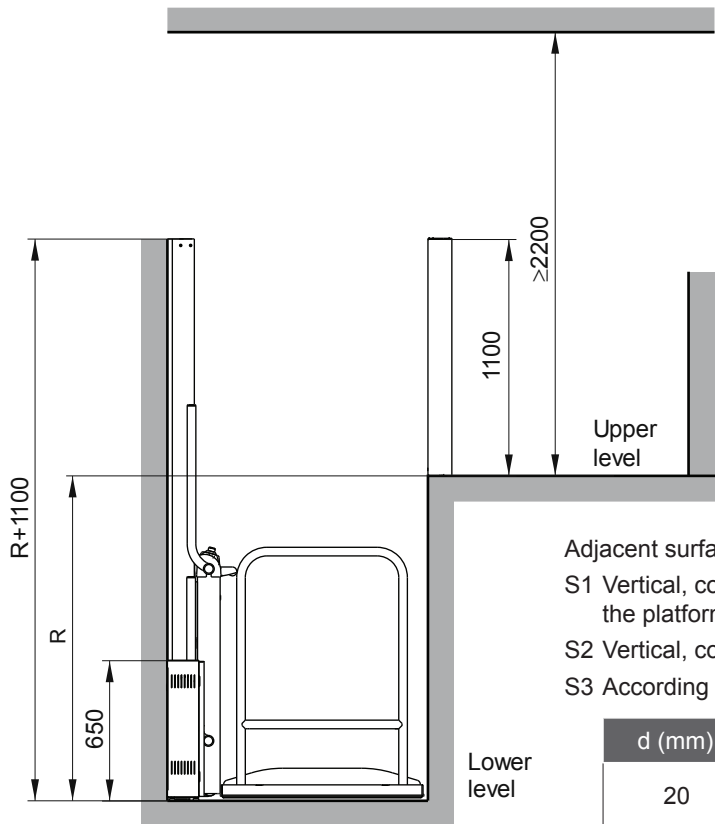

Adjacent surface requirements:

S1 Vertical, continuous, solid and smooth; throughout the length of the platform

S2 Vertical, continuous, solid and smooth

S3 According to the value of the distance to the platform (d):

d (mm)	Surface
20	Vertical, continuous, solid and smooth; throughout the dimension of the platform*
≥80	Vertical, continuous, solid and smooth
≥120	Vertical, continuous and solid
≥400	No specific requirements

* Platform without protection rail.

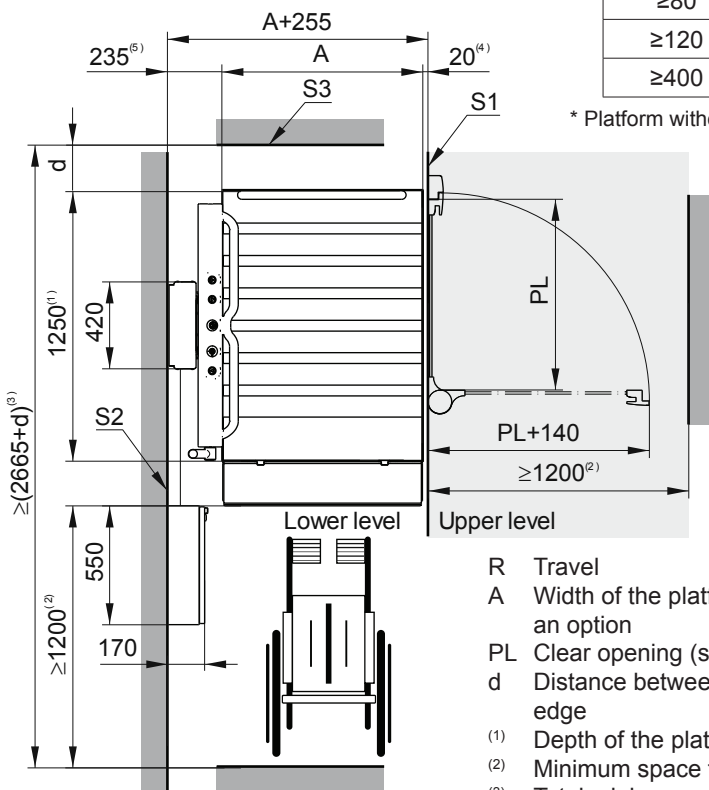

- R Travel
- A Width of the platform (standard 900 mm). Reduced width available as an option
- PL Clear opening (standard 900 mm)
- d Distance between platform and adjacent surface on the non-boarding edge
- (1) Depth of the platform
- (2) Minimum space for use with a wheelchair (recommended 1500 mm)
- (3) Total minimum space on lower level for use with a wheelchair (recommended 2965+d mm)
- (4) Distance between platform and boarding wall on the upper level
- (5) Distance between platform and fastening wall

3.5. Upper-level door

Door dimensions

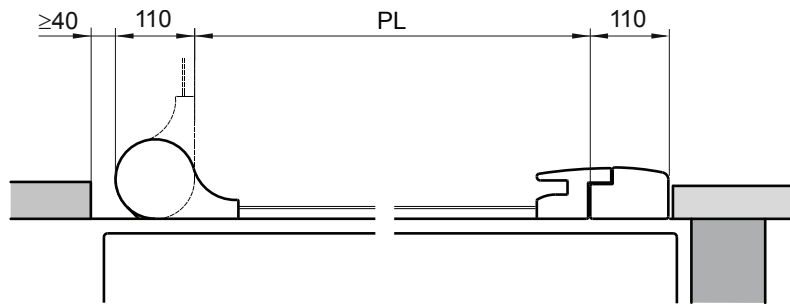

Fixation without base plate

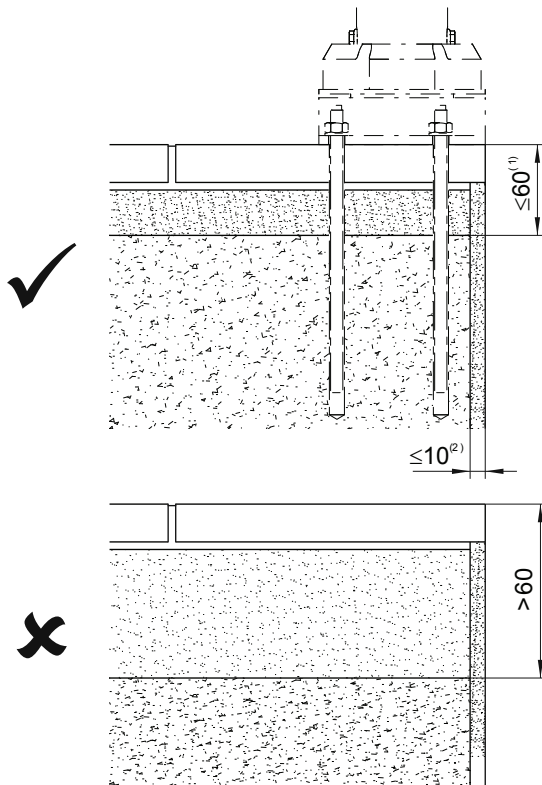

- (1) Maximum distance to concrete
- (2) Maximum thickness of the wall coating or plaster

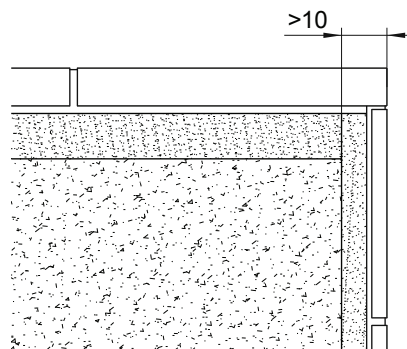

Fixation with base plate

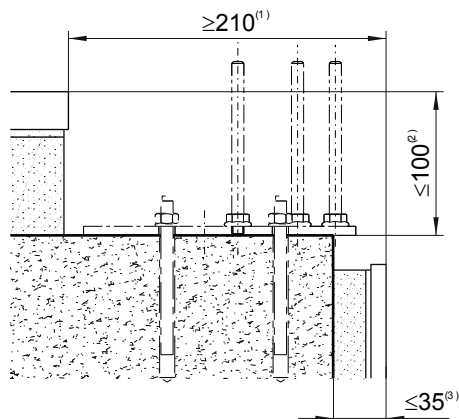

- (1) Minimum space for the installation of the base plate
- (2) Maximum distance to concrete
- (3) Maximum thickness of the wall coating or plaster

3.6. Other cabinet locations

On the upper level, 180° accesses

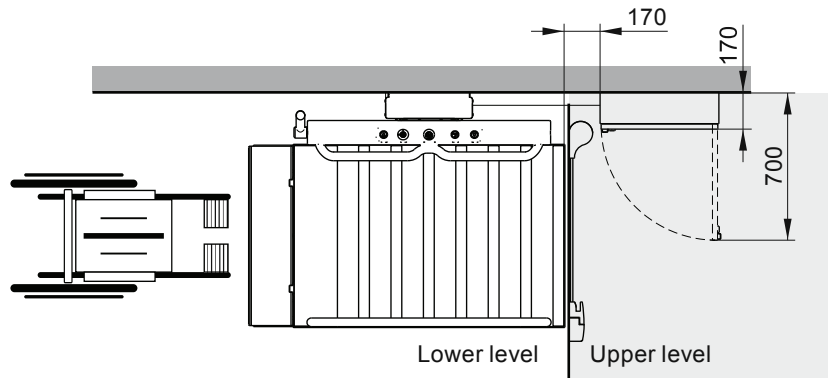

On the upper level, 90° accesses

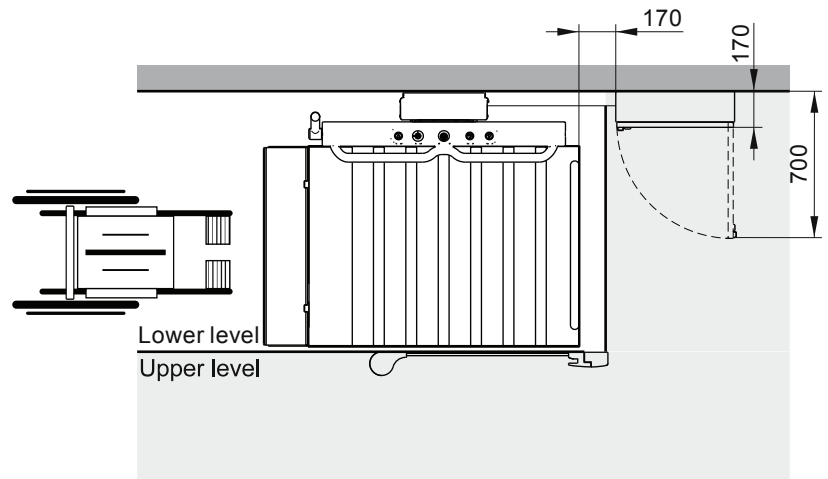

Location not adjacent to the guide

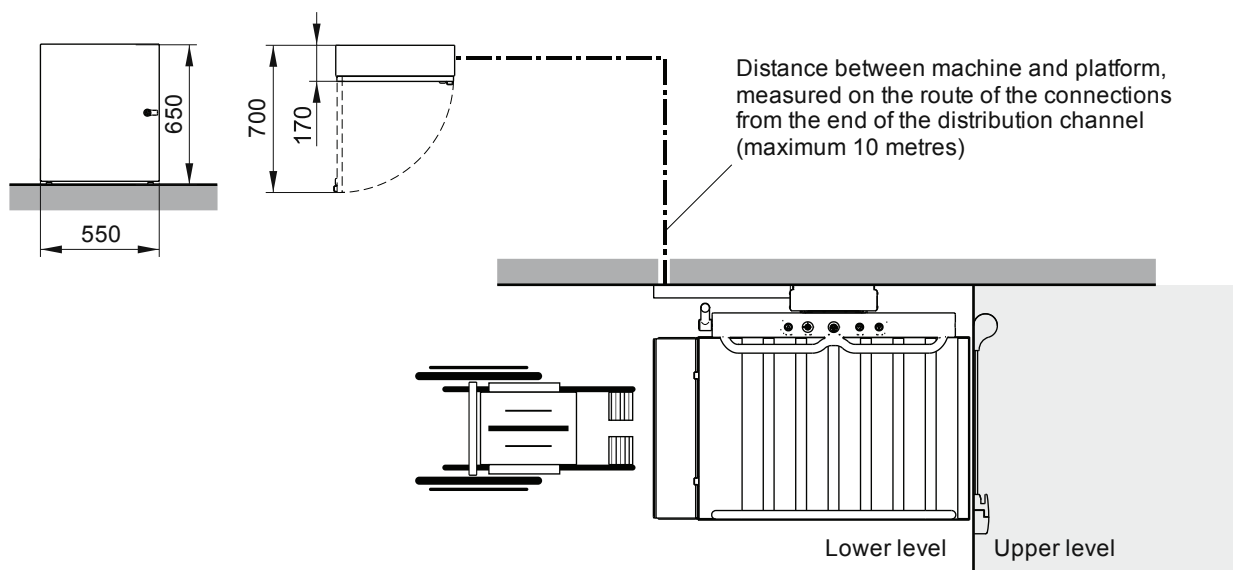

Hidral, S.A.

Polígono Industrial PARSI, Calle 7, 3
41016 - Sevilla (España)
t.+34 954 514 500 f.+34 954 677 633
www.hidral.com